

व्यावसायिक परीक्षण रिपोर्ट (प्रारंभिक)
COMMERCIAL TEST REPORT
(Initial)



संख्या/No.: MISC/NERFMTTI, B. Chariali/
09/09/568
माह / Month: March 2026

THIS TEST REPORT IS VALID UPTO 31.03.2033



VINGLOB GREENTECH (I) PVT. LTD., VGT CC 1.0, CHAFF CUTTER



सत्यमेव जयते

भारत सरकार

GOVERNMENT OF INDIA

कृषि एवं किसान कल्याण मंत्रालय

MINISTRY OF AGRICULTURE AND FARMERS WELFARE

कृषि एवं किसान कल्याण विभाग

DEPARTMENT OF AGRICULTURE AND FARMERS WELFARE

उत्तर पूर्वी क्षेत्र कृषि यंत्र प्रशिक्षण एवं परीक्षण संस्थान

NORTH EASTERN REGION FARM MACHINERY TRAINING & TESTING INSTITUTE

बिश्वनाथ चारिआलि, जिला - बिश्वनाथ(असम)

BISWANATH CHARIALI, DIST- BISWANATH, ASSAM, PIN - 784 176

[AN ISO 9001:2015 CERTIFIED INSTITUTION]

Name and address of applicant	: VINGLOB GREENTECH (I) PVT LTD, A/2 Bharat Small Industrial Estate, B/H Gujarat Off Set, Vatva, Ahmedabad, Gujarat- 382 445
Name of machine	: Chaff cutter
Type of machine	: Power operated (electric motor), cylinder type, chute-fed, throw away type
Year of manufacture	: 2026
Serial no. of machine	: 1002
Country of origin	: INDIA
Suitability of machine (apa)	: Chopping of green and dry fodder

4.2 Constructional details:

4.2.1 Main frame/stand:

Constructional details	: It was fabricated from MS angle iron having 4 legs of size 585 x 39/39 x 5.6 mm. The legs were further supported with MS angle iron 295 x 39/39 x 5.6 mm (2 Nos.).
For motor mounting	: MS angle iron 567 x 39/39 x 5.6 mm (2 Nos.).
Slot size (mm)	: 79.6 x 8.7 - 2 Nos. 99.7 x 8.7 - 2 Nos.
Size of platform (mm)	: 250 x 410
Height of platform from ground level (mm)	: 575

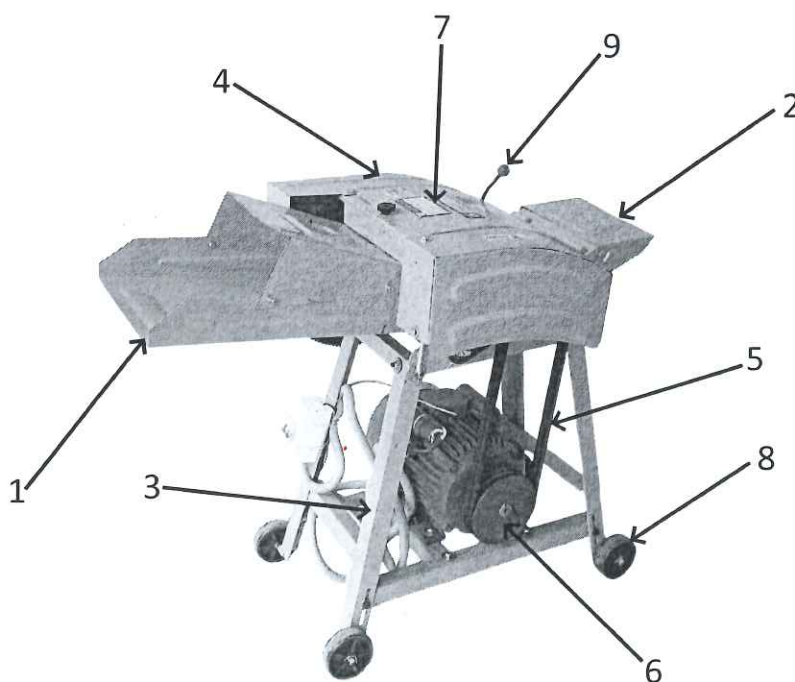

Fig.1. VINGLOB GREENTECH (I) PVT. LTD., VGT CC 1.0, CHAFF CUTTER

7. FIELD PERFORMANCE TEST

7.1 Test at no-load:

The chaff cutter was operated at no-load for 1 hour.

7.1.1 Power consumption:

The average no load power consumption of chaff cutter was recorded as 0.65 kW.

7.1.2 Visual observations:

During the no-load test, the observations against the following points were made:

Sr. No.	Parameters	Observations
(a)	Presence of any marked oscillation during operation	No
(b)	Presence of knocking or rattling sound	No
(c)	Frequent slippage of belts	No
(d)	Smooth running of shaft/shafts in their respective bearings	Satisfactory
(e)	Any marked unusual wear or slackness in any component	No
(f)	Any marked rise in bearing temperature	No
(g)	Motor speed (rpm)	1493
(h)	Fly wheel/ cylinder speed (rpm)	1222
(i)	Feed roller speed (rpm)	217

7.2 Tests at load:

7.2.1 Short run test:

Four tests of short run were carried out for cutting *Napier* grass. The detailed parameters of fodder crop are given in Annexure-I and summarized in Table-1. The detailed observations made during the test are given in Annexure-II and summarized in Table-2.

SUMMARY OF FODDER CROP PARAMETER

Table - 1

Sr. No.	Parameters	Observations
1	Name of fodder crop	<i>Napier</i> grass
2	Av. length of stalk (m)	2.10 to 3.37
3	Av. dia. of stalk (mm)	13.00 to 18.34
4	Av. moisture content (%)	64 to 67

SUMMARY OF PERFORMANCE RESULTS

Table - 2

Sr. No.	Parameters	Observations
1	Feed rate (kg/h)	200.96 to 210.60
2	Quantity of cut (kg/h)	183.01 to 195.80
3	Quality of cut	- 9.44 to - 9.76
4	Av. cut length of fodder pieces (mm)	16.82 to 20.54
5	Power consumed by chaff cutter for cutting of fodder (kW)	0.4 to 0.5
6	Total power consumed at load (kW)	1.1 to 1.2

7	Quantity of cut chaff per unit energy consumed (kg/kWh)	420.00 to 508.08
8	Corrected quantity of cut (kg/h)	69.26 to 88.32
9	Corrected quality of cut (kg/kWh)	160.84 to 176.64
10	Performance index	- 4836.87 to - 3806.96

7.2.1.1 Quantity of cut:

- The feed rate was observed as 200.96 to 210.60 kg/h.
- The quantity of cut fodder received was measured as 183.01 to 195.80 kg/h.
- The corrected quantity of cut was recorded as 69.26 to 88.32 kg/h.
- The quantity of cut per unit energy consumed was recorded as 420.00 to 508.08 kg/kWh.
- The corrected quality of cut per unit energy consumed was recorded as 160.84 to 176.64 kg/kWh.

7.2.1.2 Quality of cut:

The quality of cut was determined from the standard deviation of measured length of cut of plastic pieces. The quality of cut was ranged from - 9.44 to - 9.76.

7.2.1.3 Power requirement:

The power consumed by the chaff cutter was calculated after deducting the no-load power consumption of chaff cutter from the power consumption on load and it was measured as 0.4 to 0.5 kW.

7.2.1.4 Performance index:

The overall performance of the chaff cutter was determined by its performance index and it was calculated as - 4836.87 to - 3806.96.

7.2.2 Long run test:

The chaff cutter was operated for a total duration of 25.17 hours for cutting *Napier* grass. No breakdown in the cutter head, feeding mechanism, transmission systems and body of the chaff cutter was noticed during field performance test. No repair was occurred during the entire course of test. Percent variation in length of cut was observed as 18.0 to 21.7.

7.2.3 Labour requirement:

Three labours are required for continuous operation of the chaff cutter. Two labours are required for feeding and supplying the fodder crop and one for handling the chaff.

7.2.4 Ease of operation, adjustments and safety provisions:

- The machine was easy for installation and operation.
- The adjustment of clearance between shear plate and rotating blade was easy to perform.
- The cutter head and main power transmission were guarded by providing safety covers.
- The feed rollers were provided with spring loaded arrangement.
- The chaff cutter was provided with side plates and top cover plates to protect the feed rollers.

7.2.5 Wear analysis of blades:

Sr. No.	Initial mass (g)	Final mass (g)	Loss of mass (g)	Percentage of wear	Percentage of wear per hour after 25.17 h of operation
1	434.30	430.2	4.1	0.94	0.04
2	459.40	455.6	3.8	0.83	0.03
3	427.80	424.1	3.7	0.86	0.03
4	451.40	447.8	3.6	0.80	0.03

8. EASE OF OPERATION AND ADJUSTMENTS

No noticeable difficulty was observed during the operation and adjustment of the machine.

9. DEFECTS, BREAKDOWNS AND REPAIRS

- During field performance test it was observed that the motor capacitor was emitting some smoke and it was replaced with new one on request of the applicant.
- During field performance test it was observed that the chaff cutter was unable to cut the crop properly, hence on request of the applicant the motor pulley was replaced with new one.

10. CRITICAL TECHNICAL SPECIFICATIONS

(Vide Ministry's letter No. 13-9/2019-(M&T) (I&P)-Part dated 26.04.2019)

Sr. No.	Type	Specifications	Observed	Remarks
1	2	3	4	5
1	Type	Power operated	Power operated	Conforms
2	Basis of cutting mechanism type	Fly wheel or cylinder	Cylinder	Conforms
3	Basis of cut chaff dropping position type	Let fall, throw away or blow	Throw away type	Conforms
4	Material of blade	Mn42	High carbon steel	Does not conform
5	Hardness of blade	48-52 HRC	30 HRC	Does not conform
6	Length of conveyor, mm	1200 (Min.)	NA	--
7	Length of chute, mm	900 (Min.)	505	Does not conform
8	Thickness of chute sheet, mm	>1.6	1.67	Conforms
9	Covering of chute or conveyor, mm	450 (Min)	250	Does not conform
10	Height of feeding unit, mm	750 to 1100	750	Conforms

1	2	3	4	5
11	Cautionary notice	Must be provided	Provided	Conforms
12	Marking/labeling of machine	The labeling plate should be riveted on the body of the machine having name and address of manufacturer, country of origin, make, model, year of manufacture, serial number, Type, Require size of prime mover (kW)	Name and address of manufacturer, type and required size of prime mover (kW) were not provided.	Does not conform
13	Literature	Operator manual, service manual and parts catalogue should be provided.	Provided	Conforms

11. COMMENTS AND RECOMMENDATIONS

- 11.1** During field performance test it was observed that the motor capacitor was emitting some smoke and it was replaced with new one. This should be looked into for improvement.
- 11.2** During field performance test it was observed that the chaff cutter was unable to cut the crop properly, hence on request of the applicant the motor pulley was replaced with new one. This should be looked into for improvement.
- 11.3** **Following modifications/improvements are required as per IS 11459 : 2024.**
- 11.3.1** A warning roller with spring was not fitted before the feeding rollers to warn the operator while feeding the fodder crop into the chaff cutter. This should be looked into for corrective action.
- 11.3.2** A suitable arrangement was not provided for clutching or declutching of drive in transmission system. This should be looked into for corrective action.
- 11.3.3** Provision for adjustment of feed rate and direction of rotation of feed rollers should be provided.
- 11.3.4** Diameter of cylinder pulley shall be minimum 265 mm. This should be looked into for corrective action.
- 11.3.5** The minimum length of feeding chute shall be 900 mm. This should be looked into for corrective action.
- 11.3.6** The chute shall be covered up to a minimum of 450 mm near feed roll side. This should be looked into for corrective action.
- 11.3.7** Hooks at suitable places may be provided for lifting the chaff cutter for easy movement.
- 11.3.8** The hardness and chemical composition of blade was not met with the requirement of IS 11459 : 2024. This should be looked into for corrective action.
A minimum cautionary notice worded as per IS 11459 : 2024 shall be written in vernacular language legibly and permanently on the main body of the chaff cutter.
- 11.4** **Marking /labeling:**
The labeling plate was not provided with information such as country of origin, type, required size of prime mover (kW), code and batch number and recommended rpm of the cylinder. This should be looked into for corrective action.

- 11.5** **Adequacy of Literature:**
The following literature in English language was provided for reference during testing:
- Operator's/ Service manual
 - Parts catalogue
- It is recommended to bring out the manual in Hindi and other vernacular languages as per IS: 8132-2023.

TESTING AUTHORITY

(M.R. PATIL)
SENIOR AGRICULTURAL ENGINEER

(P. KAMALABAI)
DIRECTOR

Draft test report compiled by - Sh. D. Deori, Technical Assistant

12. APPLICANT'S COMMENTS

We have gone through the comments and recommendations as stated in the draft test report and we will take care as per comments and recommendations in our future products.

ANNEXURE - I

FODDER CROP PARAMETERS

Place of test: Kanyaka Farm, Jamugurihat, Dist. - Sonitpur, Assam

Sr. No.	Parameters	No. of tests			
		I	II	III	IV
1	Date of test	02.03.2026	03.03.2026	05.03.2026	09.03.2026
2	Name of the fodder crop	<i>Napier grass</i>			
3	Moisture content of fodder crop (%)	64	64	65	67
4	Av. length of stalk (m)	2.10	2.34	3.37	3.21
5	Av. dia. of stalk (mm)	13.00	13.14	17.44	18.34

ANNEXURE - II

PERFORMANCE TEST RESULTS

Place of test: Kanyaka Farm, Jamugurihat, Dist. - Sonitpur, Assam

Sr. No.	Parameters	No. of tests			
		I	II	III	IV
1	Name of the crop	<i>Napier grass</i>			
2	Date of test	02.03.2026	03.03.2026	05.03.2026	09.03.2026
3	Duration of test (h)	1.00	1.02	1.03	1.02
4	Feed rate (kg/h)	210.60	209.26	203.95	200.96
5	Quantity of cut (kg/h)	195.80	183.01	189.83	185.31
6	Quality of cut	- 9.76	- 9.48	- 9.52	- 9.44
7	Av. cut length of fodder pieces (mm)	17.12	18.63	20.54	16.82
8	Power consumed by chaff cutter (kW)	0.5	0.5	0.4	0.5
9	Quantity of cut per unit energy consumed (kg/kWh)	420.00	416.16	508.08	421.28
10	Corrected quantity of cut (kg/h)	88.32	80.42	69.26	82.65
11	Corrected quality of cut (kg/kWh)	176.64	160.84	173.15	165.30
12	Performance Index	- 4099.20	- 3945.20	- 4836.87	- 3806.96