



**New Swan (NSERT 125) Rotavator**

*Lib. copy*

NERFMTTI LIBRARY  
SERIAL 1811  
DATE 28/8/15



सत्यमेव जयते

भारत सरकार

GOVT OF INDIA

कृषि मन्त्रालय

MINISTRY OF AGRICULTURE

कृषि एवं सहकारिता विभाग

DEPARTMENT OF AGRICULTURE AND COOPERATION

उत्तर पूर्वी क्षेत्र कृषि यंत्र प्रशिक्षण एवं परीक्षण संस्थान

NORTH EASTERN REGION FARM MACHINERY TRAINING & TESTING INSTITUTE

विश्वनाथ चारिआलि, जिला-शोणितपुर (असम)

BISWANATH CHARIALI :: SONITPUR :: ASSAM, PIN - 784 176

Ph. No. 03715-222094

Website: <http://nerfmtti.dacnet.nic.in>

Fax No: 03715-230358

E-Mail: [fmti-ner@nic.in](mailto:fmti-ner@nic.in)

## 1. SCOPE OF TEST

The scope of test was to check and assess the following: -

### **1.1 LABORATORY TEST:**

- Checking of specifications
- Hardness of soil engaging parts (Rotavator blades)
- Chemical analysis of critical components (Rotavator blades)
- Wear analysis of critical components (Rotavator blades)

### **1.2 FIELD TEST:**

- Rate of work
- Quality of work
- Ease of operation, maintenance and adjustments
- Labour requirement
- Defects, Breakdowns & Repairs

## 2. METHOD OF SELECTION

The implement was directly submitted by the applicant for test at this Institute, hence method of selection does not arise.

## 3. TEST PROCEDURES

- i) IS: 6690-2002 : Specifications of blades for rotavator and power tillers
- ii) IS: 4931 – 1995 : Agricultural tractors-Rear Mounted PTO
- iii) IS: 4468 – 1997 : Agricultural wheeled Tractors- Rear Mounted three point linkage. (Part-1)
- iv) IS: 11531 – 2001 : Test code for puddler

## 4. SPECIFICATIONS

### **4.1 General:**

Manufacturer	: New Swan Multitech Limited, Village Raian, Kohara-Macchiwara P.O.-Heeran, Ludhiana, Punjab-141112
Name of machine	: Rotavator
Make	: NEW SWAN
Model	: NSE RT 125 Rotavator
Type	: Gear Drive
Serial number	: NSE 004150

Year of manufacture	: 2014
Type of blade	: Hatchet (L-Type)
Working width of implement(mm)	: 1260
Recommended power source	: 30 – 35 hp Tractor
Prime mover used during test	: John Deer 5310 collar shift Tractor

#### 4.2 Constructional Details (Refer Fig.1):

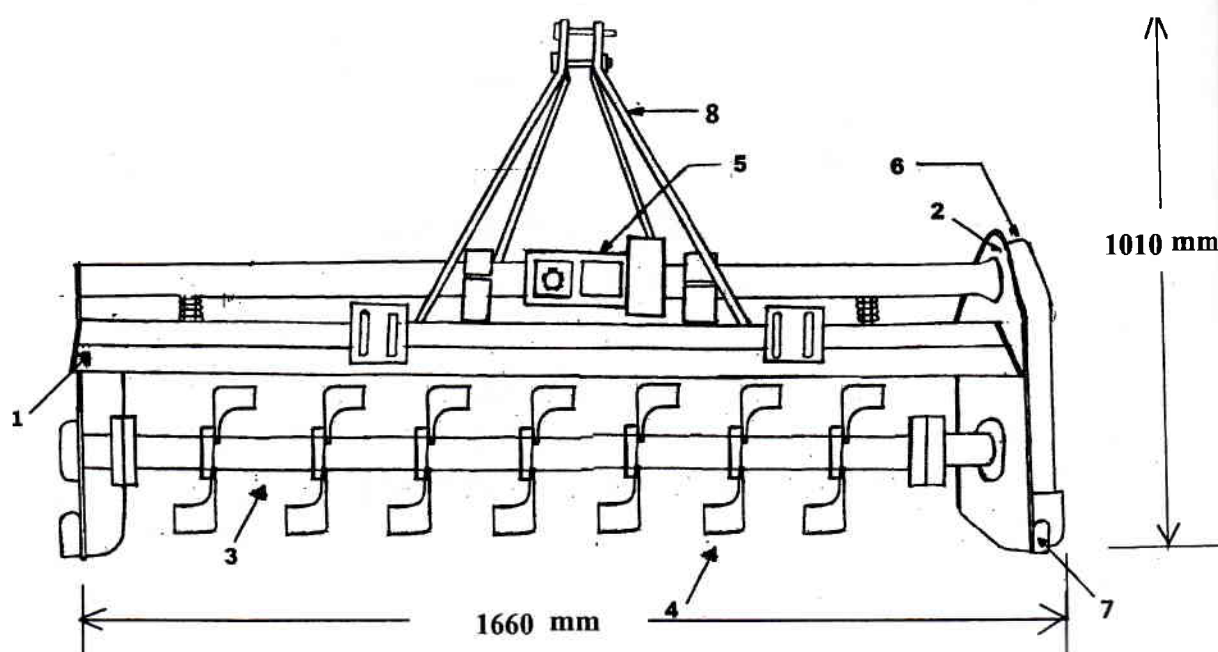

Fig.1: NEW SWAN (NSE RT 125) Rotavator

#### KEYWORDS:

- |                |                                 |
|----------------|---------------------------------|
| 1. Mainframe   | 5. Primary reduction gear box   |
| 2. Side plate  | 6. Secondary reduction gear box |
| 3. Rotor shaft | 7. Skid                         |
| 4. Rotor blade | 8. Hitch pyramid                |

**8. EFFECTIVENESS OF SEALINGS**

After completion of dry & wet land operation for 25.7 and 15.1 hours respectively, the implement was dismantled for checking the effectiveness of sealing provided against ingress of dust, and water/mud in various sub-assemblies/components. The observations are given in ensuing table:

SL No.	Location	Whether ingress of mud and/or water was observed (Yes/No)
1.	Primary reduction gear box	No
2.	Secondary reduction gear box	No
3.	Rotor assembly (hub)	No

**9. EASE OF OPERATION & ADJUSTMENTS**

No noticeable difficulty was observed during the operation and adjustment of rotavator.

**10. DEFECTS, BREAKDOWNS AND REPAIRS**

No noticeable defect or breakdown was observed during 40.8 hours of field operation.

**11. COMMENTS AND RECOMMENDATIONS**

- 11.1 The specifications of implement hitch, does not conform to the IS: 4468 (Part-1)-1997. Hence, it is recommended that implement should be provided with the hitch conforming to relevant Indian Standards.
- 11.2 Dimensions of PIC of implement does not conform to IS: 4931-1995 and therefore, it should be looked into for corrective action.
- 11.3 Chemical composition of rotor blade does not conform to IS: 6690-2002. This needs to be looked into for corrective action in production level.
- 11.4 Size of implement and power requirement should also be indicated on the labeling plate.
- 11.5 **Technical literature:**  
A booklet, named Instruction manual and Parts list was provided for reference during testing. Hence, other literature such as parts catalogue, service manual etc. should also be provided with the implement.  
However, it is recommended to bring out the manuals also in Hindi and other vernacular languages as per IS: 8132-1999.

**12. APPLICANTS COMMENTS**

No comments have been received from the applicant on this machine.