

THIS TEST REPORT IS VALID UPTO 31.03.2032



GAJA HITECH AGRO, GJ-C350, CHAFF CUTTER



सत्यमेव जयते

भारत सरकार

GOVERNMENT OF INDIA

कृषि एवं किसान कल्याण मंत्रालय

MINISTRY OF AGRICULTURE AND FARMERS WELFARE

कृषि एवं किसान कल्याण विभाग

DEPARTMENT OF AGRICULTURE AND FARMERS WELFARE

उत्तर पूर्वी क्षेत्र कृषि यंत्र प्रशिक्षण एवं परीक्षण संस्थान

NORTH EASTERN REGION FARM MACHINERY TRAINING & TESTING INSTITUTE

बिश्वनाथ चारिआलि, जिला - बिश्वनाथ(असम)

BISWANATH CHARIALI, DIST- BISWANATH, ASSAM, PIN - 784 176

[AN ISO 9001:2015 CERTIFIED INSTITUTION]

Machine 157/531	GAJA HITECH AGRO, GJ-C350 CHAFF CUTTER	COMMERCIAL (INITIAL)
-----------------	---	-------------------------

Name and address of applicant : M/s DVJ ASSOCIATES PRIVATE LIMITED, SF 452/5B Senthur Garden, 46 Pudur Village Pudur, Erode, Tamil Nadu - 638002

Name of machine : Chaff Cutter

Type of machine : Power operated (electric motor), Cylinder type, Chute-fed, Throw away type

Year of manufacture : 2024

Serial no. of machine : 24-11-072

Country of origin : CHINA

Suitability of machine (apa) : Chopping of green and dry fodder

4.2 Constructional details:

4.2.1 Main frame/Stand:

Constructional details : It is fabricated from MS angle iron having 4 legs of size 523 x 47/47 x 3.1 mm. The legs are further supported with MS angle iron 285 x 37/37 x 2.5 mm widthwise (2 Nos.).

For motor mounting : 435 x 37/37 x 2.2 mm - 02 Nos.

Slot size (mm) : 84 x 9.5- 4 Nos.

Size of platform (mm) : 245 x 395

Height of platform from ground level (mm) : 515

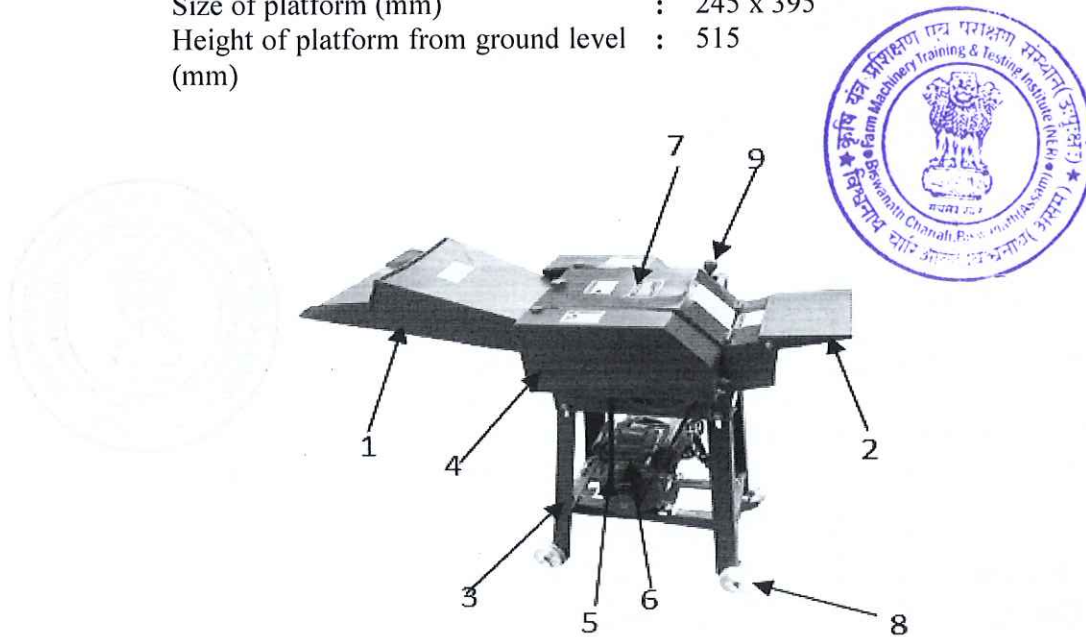

Fig.1. GAJA HITECH AGRO, GJ-C350, CHAFF CUTTER

Keywords:

- | | |
|-----------------------------|------------------------|
| 1. Feeding chute | 2. Outlet trough |
| 3. Main Frame/Stand | 4. Pulley Safety Cover |
| 5. Pulley belt | 6. Electric motor |
| 7. Cutter head Safety Cover | 8. Transport wheels |
| 9. Gear shifting lever | |

Machine 157/531	GAJA HITECH AGRO, GJ-C350 CHAFF CUTTER	COMMERCIAL (INITIAL)
-----------------	---	-------------------------

7. FIELD PERFORMANCE TEST

7.1 Test at No-Load:

The chaff cutter was operated at no-load for 0.5 hour.

7.1.1 Power Consumption:

The no load power consumption of chaff cutter was recorded as 0.8 kW

7.1.2 Visual Observations:

During the No-load test, the observations against the following points were made:

Sr. No.	Parameters	Observations
(a)	Presence of any marked oscillation during operation	No
(b)	Presence of knocking or rattling sound	No
(c)	Frequent slippage of belts	No
(d)	Smooth running of shaft/shafts in their respective bearings	Satisfactory
(e)	Any marked unusual wear or slackness in any component	No
(f)	Any marked rise in bearing temperature	No
(g)	Motor Speed (rpm)	2989
(h)	Fly wheel/ cylinder speed (rpm)	1047
(i)	Feed roller speed (rpm)	262

7.2 Tests at Load:

7.2.1 Short run test:

Four tests of short run were carried out for cutting Napier grass. The detailed parameters of fodder crop are given in Annexure-I and summarized in Table-1. The detailed observations made during the test are given in Annexure-II and summarized in Table-2

SUMMARY OF FODDER CROP PARAMETER

Table - 1

Sr. No.	Parameters	Observations
1	Name of fodder crop	Napier grass
2	Av. length of stalk (m)	2.8 to 3.0
3	Av. dia. of stalk (mm)	14.2 to 16.2
4	Av. moisture content (%)	57 to 67

SUMMARY OF PERFORMANCE RESULTS

Table - 2

Sr. No.	Parameters	Observations
1	Feed rate (kg/h)	295.0 to 330.0
2	Quantity of cut (kg/h)	285.5 to 330.0
3	Quality of cut	-8.97 to -11.07
4	Av. cut length of fodder pieces (mm)	21.3 to 22.9
5	Power consumed by chaff cutter for cutting of fodder (kW)	0.3 to 0.4
6	Total power consumed at load (kW)	1.1 to 1.2



Machine 157/531	GAJA HITECH AGRO, GJ-C350 CHAFF CUTTER	COMMERCIAL (INITIAL)
-----------------	---	-------------------------



7	Quantity of cut chaff per unit energy consumed (kg/kWh)	713.8 to 1100.0
8	Corrected quantity of cut (kg/h)	87.6 to 123.9
9	Corrected quality of cut (kg/kWh)	219.0 to 413.0
10	Performance Index	-6402.3 to -12177.0

7.2.1.1

Quantity of cut:

- The feed rate was observed as 295.0 to 330 kg/h.
- The quantity of cut fodder received was measured as 285.5 to 330.0 kg/h.
- The corrected quantity of cut was recorded as 87.6 to 123.9 kg/h.
- The quantity of cut per unit energy consumed was recorded as 713.8 to 1100.0 kg/kWh.
- The corrected quality of cut per unit energy consumed was recorded as 219.0 to 413.0 kg/kWh.

7.2.1.2

Quality of cut:

The quality of cut was determined from the standard deviation of measured length of cut of plastic pieces. The quality of cut was ranged from -8.97 to -11.07.

7.2.1.3

Power requirement:

The power consumed by the chaff cutter was calculated after deducting the no-load power consumption of chaff cutter from the power consumption on load and it was measured as 0.3 to 0.4 kW.

7.2.1.4

Performance index:

The overall performance of the chaff cutter was determined by its performance Index and it was calculated as -6402.3 to -12177.0.

7.2.2

Long run test:

The chaff cutter was operated for a total duration of 20.0 hours for cutting Napier grass. No breakdown in the cutter head, feeding mechanism, transmission systems and body of the chaff cutter was noticed.

No repair was occurred during the entire course of test.

Percent variation in length of cut was observed as 17.0 to 21.9.

7.2.3

Labour requirement:

Three labours are required for continuous operation of the chaff cutter. Two labours are required for feeding and supplying the fodder crop and one for handling the chaff.

7.2.4

Ease of operation, adjustments and safety provisions:

- The machine is easy for installation and operation.
- The adjustment of clearance between shear plate and rotating blade is easy to perform.
- The cutter head and main power transmission are guarded by providing safety covers.
- The feed rollers are provided with spring loaded arrangement.
- The Chaff Cutter is provided with side plates and top cover plates to protect the feed rollers.

Machine 157/531	GAJA HITECH AGRO, GJ-C350 CHAFF CUTTER	COMMERCIAL (INITIAL)
-----------------	---	-------------------------

7.2.5 Wear analysis of blades:

Sr. No.	Initial mass, (g)	Final mass, (g)	Loss of mass (g)	Percentage of wear	Percentage of wear per hour after 24.10 h of operation
1	573.18	571.29	1.89	0.33	0.01
2	575.55	573.24	2.31	0.40	0.02
3	561.64	559.65	1.99	0.35	0.01
4	569.66	567.55	2.11	0.37	0.02

8. EASE OF OPERATION AND ADJUSTMENTS

No noticeable difficulty was observed during the operation and adjustment of the machine.

9. DEFECTS, BREAKDOWNS AND REPAIRS

No defects and breakdowns were observed during the entire test.

10. CRITICAL TECHNICAL SPECIFICATIONS

(Vide Ministry's letter No. 13-9/2019-(M&T) (I&P)-Part dated 26.04.2019)



Sr. No.	Type	Specifications	Observed	Remarks
1	2	3	4	5
1	Type	Power operated	Power operated	Conforms
2	Basis of cutting mechanism type	Fly wheel or cylinder	Cylinder	Conforms
3	Basis of cut chaff dropping position type	Let fall, throw away or blow	Throw away type	Conforms
4	Material of blade	Mn42	Carbon steel	Does not conform
5	Hardness of blade	48-52 HRC	204 HB	Does not conform
6	Length of conveyor, mm	1200 (Min.)	NA	--
7	Length of chute, mm	900 (Min.)	600	Does not conform
8	Thickness of chute sheet, mm	>1.6	1.2	Does not conform
9	Covering of chute or conveyor, mm	450 (Min)	390	Does not conform
10	Height of feeding unit, mm	750 to 1100	775	Conforms

Machine 157/531	GAJA HITECH AGRO, GJ-C350 CHAFF CUTTER	COMMERCIAL (INITIAL)
-----------------	---	-------------------------

1	2	3	4	5
11	Cautionary notice	Must be provided	Provided	Conforms
12	Marking/labeling of machine	The labeling plate should be riveted on the body of the machine having name and address of manufacturer, country of origin, make, model, year of manufacturer, serial number, Type, Require size of prime mover (kW)	Address of manufacturer, country of origin, and type were not provided.	Does not conform
13	Literature	Operator manual, service manual and parts catalogue should be provided.	Provided	Conforms



11. COMMENTS AND RECOMMENDATIONS

11.1 Following modifications/improvements are required as per IS 11459 : 2024.

- 11.1.1 A warning roller with spring was not fitted before the feeding rollers to warn the operator while feeding the fodder crop into the chaff cutter. This should be looked into for corrective action.
- 11.1.2 A suitable arrangement was not provided for clutching or declutching of drive in transmission system. This should be looked into for corrective action.
- 11.1.3 The power source shall be mounted on a frame made of MS angle with minimum thickness of 5 mm. This should be looked into for corrective action.
- 11.1.4 Pulley diameter of power source shall be of 100 mm. This should be looked into for corrective action.
- 11.1.5 Diameter of cylinder pulley shall be minimum 265 mm. This should be looked into for corrective action.
- 11.1.6 The minimum length of chute shall be 900 mm. This should be looked into for corrective action.
- 11.1.7 The chute shall be covered up to a minimum of 450 mm near feed roll side. This should be looked into for corrective action.
- 11.1.8 Provision to change the direction of rotation of feed rolls should be provided.
- 11.1.9 Hooks at suitable places may be provided for lifting the chaff cutter for easy movement.
- 11.1.10 The thickness of the chute cover shall not be less than 1.6 mm
- 11.1.11 The height of feeding chute of chaff cutter should be between 750 to 1100 mm
- 11.1.12 The hardness of blade was not met with the requirement of IS 11459 : 2024. This should be looked into for corrective action.

11.2 Marking /labeling:

The labeling plate was not provided with information such as manufacturer's name or registered trade mark, code and batch number, type, rated input capacity and recommended rpm of the cylinder. This should be looked into for corrective action.

Machine 157/531	GAJA HITECH AGRO, GJ-C350 CHAFF CUTTER	COMMERCIAL (INITIAL)
-----------------	---	-------------------------

11.3 Adequacy of Literature:

The following literature in English language was provided for reference during testing:

- Operator's/ Service manual
- Parts catalogue

It is recommended to bring out the manual in Hindi and other vernacular languages as per IS: 8132-2023.

TESTING AUTHORITY



**(M.R. PATIL)
SENIOR AGRICULTURAL ENGINEER**



**(P. KAMALABAI)
DIRECTOR**

Draft test report compiled by - **Sh. Vithato Keyho, Sr. Technical Assistant**

12. APPLICANT'S COMMENTS

Applicant's Comments
We have gone through your comments and recommendations we will do the necessary action in future products.

Machine 157/531	GAJA HITECH AGRO, GJ-C350 CHAFF CUTTER	COMMERCIAL (INITIAL)
-----------------	---	-------------------------

ANNEXURE – I

FODDER CROP PARAMETERS

Place of test: Kanyaka Farm, Jamugurihat, Dist. – Sonitpur, Assam

Sr. No.	Parameters	No. of tests			
		I	II	III	IV
1	Date of test	18.03.2025	19.03.2025	20.03.2025	21.03.2025
2	Name of the fodder crop	Napier grass			
3	Moisture content of fodder crop (%)	63	60	67	57
4	Av. length of stalk (m)	3.0	2.9	2.8	2.9
5	Av. dia. of stalk (mm)	16.2	14.2	14.5	14.9

ANNEXURE – II

PERFORMANCE TEST RESULTS

Place of test: Kanyaka Farm, Jamugurihat, Dist. – Sonitpur, Assam

Sr. No.	Parameters	No. of tests			
		I	II	III	IV
1	Name of the crop	Napier grass			
2	Date of test	18.03.2025	19.03.2025	20.03.2025	21.03.2025
3	Duration of test (h)	1.00	1.07	1.03	1.00
4	Feed rate (kg/h)	300.0	295.7	295.0	330.0
5	Quantity of cut (kg/h)	300.0	290.6	285.5	330.0
6	Quality of cut	-9.57	-10.00	-8.97	-11.07
7	Av. cut length of fodder pieces (mm)	22.5	21.3	21.5	22.9
8	Power consumed by chaff cutter (kW)	0.4	0.4	0.4	0.3
9	Quantity of cut per unit energy consumed (kg/kWh)	750.0	726.5	713.8	1100.0
10	Corrected quantity of cut (kg/h)	98.7	109.1	87.6	123.9
11	Corrected quality of cut (kg/kWh)	246.8	272.8	219.0	413.0
12	Performance Index	-7177.5	-7265.0	-6402.3	-12177.0

