

व्यावसायिक परीक्षण रिपोर्ट (प्रारंभिक)  
COMMERCIAL TEST REPORT  
(Initial)



संख्या/No.: MISC/NERFMTTI, B. Chariali/  
10/10/569  
माह / Month: March 2026

THIS TEST REPORT IS VALID UPTO 31.03.2033



AGRI IGNITE VENTURES, CGTB43, BRUSH CUTTER



सत्यमेव जयते

भारत सरकार

GOVERNMENT OF INDIA

कृषि एवं किसान कल्याण मंत्रालय

MINISTRY OF AGRICULTURE AND FARMERS WELFARE

कृषि एवं किसान कल्याण विभाग

DEPARTMENT OF AGRICULTURE AND FARMERS WELFARE

उत्तर पूर्वी क्षेत्र कृषि यंत्र प्रशिक्षण एवं परीक्षण संस्थान

NORTH EASTERN REGION FARM MACHINERY TRAINING & TESTING INSTITUTE

बिश्ननाथ चारिआलि, जिला - बिश्ननाथ(असम)

BISWANATH CHARIALI, DIST- BISWANATH, ASSAM, PIN - 784 176

[AN ISO 9001:2015 CERTIFIED INSTITUTION]

Ph. No. 03715-222094

Website: <https://nerfmitti.nic.in>

E-mail: [fmti-ner@nic.in](mailto:fmti-ner@nic.in)

Name and address of the applicant	:	Agri Ignite Ventures, Survey No. 356/2/2, AB Road, Dakachya, Indore, Madhya Pradesh – 453 771
Make	:	AGRI IGNITE VENTURES
Model	:	CGTB43
Serial No.	:	20251210006
Type	:	Self-propelled
Type of cutting attachments	:	Nylon rope (tap & go), circular blade and straight blade
Year of manufacture	:	2025
Country of origin	:	CHINA
Type of crops/bush recommended	:	All kinds of weeds/bushes

**4.2 Constructional details:**

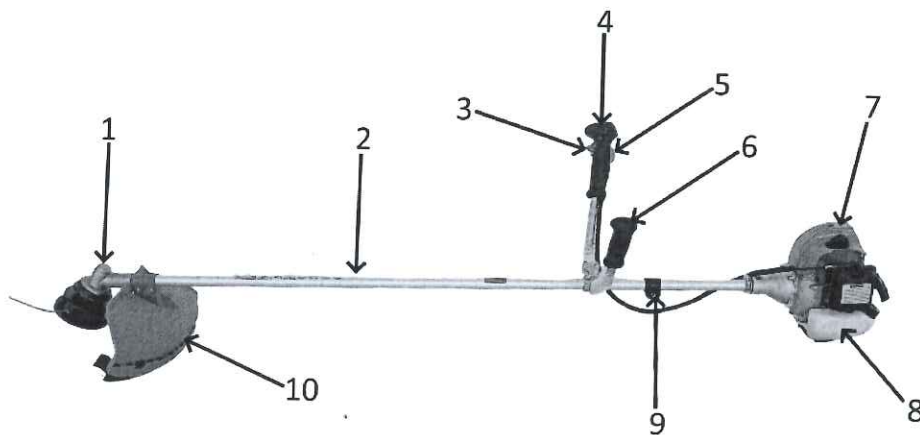

**Fig. 1: BRUSH CUTTER, MODEL: CGTB43**

**Keywords:**

- |                                |                                  |
|--------------------------------|----------------------------------|
| 1. Gear case                   | 6. LHS handle                    |
| 2. Transmission cover pipe     | 7. Engine                        |
| 3. Throttle cum clutch trigger | 8. Fuel tank                     |
| 4. RHS handle                  | 9. Connection for shoulder strap |
| 5. Engine stopping switch      | 10. Deflector                    |

10.4 **Chemical composition of circular blade:**  
The results of chemical analysis test of circular blade were as under.

Constituent	As per IS: 6025 – 2024 (%)	Composition as observed (% by weight)	Remarks
Carbon (C)	0.50 to 0.95	0.184	Does not conform
Manganese (Mn)	0.2 to 0.8	0.341	Conforms
Silicon (Si)	--	0.070	--
Sulphur (S)	--	0.012	--
Phosphorous (P)	--	0.019	--

### 11. WEAR ANALYSIS OF CRITICAL COMPONENTS

Component	Duration of operation (h)	Initial mass (g)	Mass after operation (g)	Loss of mass (g)	Percentage of wear	Percentage of wear on hourly basis
Straight blade	8.00	283.53	281.78	1.75	0.62	0.08
Circular blade	8.00	423.45	421.55	1.90	0.45	0.06

### 12. FIELD PERFORMANCE TEST

Field tests were conducted for total of 26.08 hours duration. Grass/weeds cutting with nylon rope and bush cutting with straight blade & circular blade attachment were carried out for 10.08 hours, 8.00 hours and 8.00 hours, respectively. A total of six test trials were conducted at rated engine speed of 7000 rpm. Detailed results of field tests are shown in ANNEXURE-I, II & III and summarized in the ensuing Table. Details of operation have been given in ANNEXURE-IV.

#### SUMMARY OF FIELD PERFORMANCE TEST

Sr. No.	Parameters	Grass/weeds cutting with nylon rope	Bush cutting with straight blade	Bush cutting with circular blade
1	Field Condition	Level		
2	Thickness of stem of Grass/Bush at cutting height (mm)	1.87 to 1.89	16.74 to 17.39	13.62 to 14.99
3	Number of Grass/Bush per m <sup>2</sup>	456 to 497	41 to 45	40 to 45
4	Height of Grass/Bush (mm)	201 to 247	2166 to 2765	2074 to 2088
5	Mass of Grass/Bush cut (kg/h)	424.67 to 534.18	1067.24 to 1156.89	1249.58 to 1259.88
6	Mass of Grass/Bush cut (kg/ha)	10080 to 10120	24098 to 27364	23774 to 25504

7	Rate of work (ha/h)	0.047 to 0.053	0.039 to 0.048	0.049 to 0.053
8	Time required for one hectare (h)	18.87 to 21.28	20.83 to 25.64	18.87 to 20.41
9	Fuel consumption:			
	-l/h	1.10 to 1.12	0.83 to 0.84	0.91 to 0.92
	-l/ha	20.76 to 23.83	17.50 to 21.28	17.17 to 18.78

### 12.1 Grass/Weeds cutting using nylon rope:

#### 12.1.1 Rate of work:

The area of cut was recorded as 0.047 to 0.053 ha/h.  
Time required for one hectare was recorded as 18.87 to 21.28 hours.  
Mass of weeds cut was 424.67 to 534.18 kg/h.

#### 12.1.2 Fuel consumption:

Fuel consumption was observed as 1.10 to 1.12 l/h and 20.76 to 23.83 l/ha.

### 12.2 Bush cutting using straight blade:

#### 12.2.1 Rate of work:

The area of cut was recorded as 0.039 to 0.048 ha/h.  
Time required for one hectare was recorded as 20.83 to 25.64 hours.  
Mass of weeds cut was 1067.24 to 1156.89 kg/h.

#### 12.2.2 Fuel consumption:

Fuel consumption was observed as 0.83 to 0.84 l/h and 17.50 to 21.28 l/ha.

### 12.3 Bush cutting using circular blade:

#### 12.3.1 Rate of work:

The area of cut was recorded as 0.049 to 0.053 ha/h.  
Time required for one hectare was recorded as 18.87 to 20.41 hours.  
Mass of weeds cut was 1249.58 to 1259.88 kg/h.

#### 12.3.2 Fuel consumption:

Fuel consumption was observed as 0.91 to 0.92 l/h and 17.17 to 18.78 l/ha.

### 12.4 Labour/operator requirement:

It was observed that an averagely built person can able to operate the brush cutter for 40 to 45 minutes at a stretch. Hence, two operators are required for continuous operation of the brush cutter.

### 12.5 Adequacy of prime mover power:

The power of the prime mover was found adequate.

### 13. EASE OF OPERATION AND ADJUSTMENTS

No difficulties were observed in operation and adjustment during the field test.

### 14. DEFECTS, BREAKDOWNS AND REPAIRS

No noticeable defect or breakdown was observed during test.

### 15. COMPONENTS/ASSEMBLY INSPECTION

The engine was dismantled after 37.08 hours of operation.

#### 15.1 Engine:

##### Cylinder bore:

Cylinder bore dia., mm						Max. permissible wear limit, mm
Top position		Middle position		Bottom position		
Thrust side	Non-thrust side	Thrust side	Non-thrust side	Thrust side	Non-thrust side	
40.03	40.02	40.02	40.02	40.01	40.01	40.30

##### Piston:

Piston dia., mm				Max. Permissible wear limit at skirt (mm)	Clearance between piston & cylinder liner at the skirt of the piston, mm	
Top (above top compression ring)		At skirt			As observed	Max. permissible limit (mm)
Thrust side	Non-thrust side	Thrust side	Non-thrust side			
39.74	39.76	39.94	*	Not specified	0.07	0.30

\*Not recorded due to piston design constraints

##### Ring end gap:

Rings	Ring end gap, mm			Max. permissible end gap limit, mm
	Top	Middle	Bottom	
1 <sup>st</sup> comp. ring	0.20	0.20	0.20	1.0
2 <sup>nd</sup> comp. ring	0.33	0.35	0.35	
Oil ring	NA	NA	NA	

##### Ring side clearance:

Rings	Ring side clearance, mm	Max. permissible clearance limit, mm
1 <sup>st</sup> comp. ring	0.05	0.30
2 <sup>nd</sup> comp. ring	0.05	
Oil ring	*	

\*Not recorded due to ring design constraints

Main bearings: 6202-2 Nos. of ball bearings

Bearing No.	Type of bearing	Diametrical clearance, mm	Crankshaft end float, mm	Max. permissible clearance limit, mm	
				Diametrical clearance	Crankshaft end float
1	Ball bearing	NA	0.10	NA	0.14
2	Ball bearing	NA			

#### Big end bearing:

Bearing No.	Clearance, mm		Max. permissible clearance limit, mm	
	Diametrical	Axial	Diametrical	Axial
1	Needle bearing	NR	0.15	0.70

Measurement of big end bearing clearance was not possible as the piston along with connecting rod was not detachable.

#### 15.2 Transmission system:

All the gears of the transmission system were found in normal condition.

### 16. CRITICAL TECHNICAL SPECIFICATIONS

(Vide Ministry's letter No. 13-9/2019-(M&T) (I&P)-Part dated 26.04.2019)

Sr. No.	Parameters	Specifications	Observation	Remarks
1	2	3	4	5
1	Type	Self-propelled, portable	Self-propelled, portable	Conforms
2	Type of cutting attachment	Circular disc / Straight blade /nylon rope	Straight blade/ nylon rope / circular disc	Conforms
<b>Circular blade</b>				
3	Material of circular blade	Alloy steel	Alloy steel	Conforms
4	No. of teeth on circular disc blade	50 -100	80	Conforms
5	Root diameter / Overall diameter (mm)	200 -270	253.99	Conforms
6	Thickness of disc (mm)	1.5 Min.	2.02	Conforms
7	Teeth thickness (mm)	2.0 Min.	2.02	Conforms
8	Hardness of blade, HRC	68 - 70	45.8	<b>Does not conform</b>
<b>Straight blade</b>				
9	Material of straight blade	Alloy steel	Alloy steel	Conforms

1	2	3	4	5
10	Diameter of straight blade (mm)	250 - 350	305.53	Conforms
11	Width at ends /at center (mm)	50 / 70, Min.	60.5/90.5	Conforms
12	Thickness of straight blade(mm)	1.5 Min.	2.24	Conforms
<b>Nylon rope</b>				
13	Length of nylon rope(mm)	2000 - 4000	2000	Conforms
14	Diameter of nylon rope (mm)	2.5 to 4.0	2.5	Conforms
15	Type of engine	Compression ignition / Spark ignition	Spark ignition	Conforms
16	Starting method	Manual / recoil / self -starting	Recoil starting	Conforms
17	Type of clutch	Cone / Centrifugal	Centrifugal	Conforms
18	Type of gear drive	Bevel pinion	Bevel pinion	Conforms
19	Capacity of fuel tank (l)	1.0 (Min.)	1.1	Conforms
20	On /Off provision in fuel supply system	Must be provided	Not provided	<b>Does not conform</b>
21	Provision for easy start of engine	Must be provided	Provided	Conforms
22	Provision for emergency stop of engine	Must be provided	Provided	Conforms
23	Provision for shield / cover to prevent flying of mud & stone from rotor	Must be provided	NA	--
24	Provision for Grass deflector at the rear of the cutting mechanism	Must be provided	Provided	Conforms
25	Provision for Pad with shoulder belt to dampen the vibration	Must be provided	Provided	Conforms
26	Provision for cover on exhaust	Must be provided	Provided	Conforms
27	Direction of exhaust emission away from operator	Must be provided	Provided	Conforms
28	Provision for safety kit (helmet, earplug, mask, hand gloves, safety protective cloth, safety shoes)	Must be provided	Not provided	<b>Does not conform</b>

1	2	3	4	5
29	Marking /labeling of machine	The labeling plate should be riveted on the body of machine having Name and address of manufacturer & Applicant, Country of origin, Make, Model, Year of manufacturer, Serial number, Engine number, Engine HP, rated rpm & SFC.	Name and address of manufacturer, Year of manufacture, engine number, rated rpm, engine HP & SFC were not provided on the labeling sticker. Instead of labeling plate, a sticker was pasted on the machine.	<b>Does not conform</b>
30	Literature	Operator manual, Service manual and Parts catalogue should be provided.	Provided	Conforms

### 17. COMMENTS AND RECOMMENDATIONS

- 17.1 The average rated power in rating test of engine was observed as 0.70 kW against declared value of 1.25 kW by the applicant/manufacturer. This should be looked into for corrective action.
- 17.2 The specific fuel consumption (SFC) in rating test of engine was observed as 1040 g/kWh against declared value of 750 g/kWh by the applicant/manufacturer which exceeded by more than 5 percent of that declared by the manufacturer and hence does not fulfill the requirement of IS 7347-1974 (Amended 2021). This should be looked into for corrective action.
- 17.3 Safety wears were not provided with the machine. The applicant is strictly advised to provide the entire safety kit including helmet, safety shoes, hand gloves, safety glass, ear plug, mask etc. along with each machine for the safety of operator.
- 17.4 The engine was not marked with Manufacturer name or trade-mark, Rated power, Rated speed and type of fuel used which does not fulfill the requirement of IS 7347-1974 (Amended 2021). This should be looked into.
- 17.5 On /Off provision in fuel supply system was not provided. This should be looked into for corrective action.
- 17.6 The hardness of straight blade and chemical composition of both straight and circular blade did not conform to Indian Standard IS 6025-2024. This should be looked into for corrective action.
- 17.7 Name and address of manufacturer, year of manufacture, engine number, rated rpm, engine HP and SFC were not provided on the labeling sticker. Instead of labeling plate, a sticker was pasted on the machine. This should be looked into for corrective action.
- 17.8 Noise at operator's ear level was observed on higher side against danger limit of 90 dB(A) as specified by International Labour Organization (ILO) for continuous exposure of 8 hours per day. This calls for reduction in noise level to improve the operational comfort and safety of operator.

17.9 The amplitude of mechanical vibration at various assemblies viz. engine cover, steering hand and drive shaft cover pipe were on higher side. This calls for dampening down of vibration improve the operational comfort and service life of the components.

17.10 **Adequacy of Literature:**

The following literature in English language was provided for reference during testing:

- Operator's/ Service manual
- Parts catalogue

It is recommended to bring out the manual in Hindi and other vernacular languages as per IS 8132-2023.

**TESTING AUTHORITY**

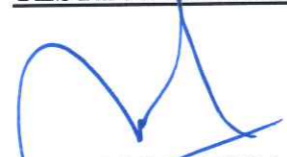
  
(M.R. PATIL)  
SENIOR AGRICULTURAL ENGINEER

  
(P. KAMALABAI)  
DIRECTOR

Draft test report compiled by - Sh. D. Deori, Technical Assistant

**18. APPLICANT'S COMMENTS**

We have gone through your comments and recommendations in Sections 17.1 to 17.10. We will take corrective action as suggested.

ANNEXURE-I

**FIELD PERFORMANCE TEST**

Cutting attachment : Nylon rope (Tap & Go)  
Place of test : Kanyaka Farm, Jamugurihat, Dist. – Sonitpur, Assam  
Usage : Weeds/grass cutting

Sr. No.	Parameters	Test trial	
		I	II
1	Date of test	11.03.2026	12.03.2026
2	Net test duration (h)	3.25	6.83
3	Avg. height of weeds (mm)	201	247
4	Avg. thickness of stem of weeds at cutting height (mm)	1.89	1.87
5	Avg. No. of weeds per m <sup>2</sup>	497	456
6	Avg. mass of weeds cut per m <sup>2</sup> (g)	1012	1008
7	Actual area cut (ha/h)	0.047	0.053
8	Time required for one ha (h/ha)	21.28	18.87
9	Mass of weeds cut		
		kg/h	424.67
		kg/ha	10120
10	Fuel consumption		
		l/h	1.12
		l/ha	23.83

ANNEXURE-II

FIELD PERFORMANCE TEST

Cutting attachment : Straight blade  
 Place of test : Kanyaka Farm, Jamugurihat, Dist. – Sonitpur, Assam  
 Usage : Bush/ Napier grass cutting

Sr. No.	Parameters	Test trial	
		I	II
1	Date of test	10.03.2026	11.03.2026
2	Net test duration (h)	5.0	3.0
3	Avg. height of bush (mm)	2765	2166
4	Avg. thickness of stem of bush at cutting height (mm)	16.74	17.39
5	Avg. No. of bush per m <sup>2</sup>	45	41
6	Avg. mass of bush cut per m <sup>2</sup> (g)	2409.8	2736.4
7	Actual area cut (ha/h)	0.048	0.039
8	Time required for one ha (h/ha)	20.83	25.64
9	Mass of bush cut		
		kg/h	1156.89
		kg/ha	24098
10	Fuel consumption		
		l/h	0.84
		l/ha	17.50

ANNEXURE-III

FIELD PERFORMANCE TEST

Cutting attachment : Circular blade  
 Place of test : Kanyaka Farm, Jamugurihat, Dist. – Sonitpur, Assam  
 Usage : Bush/ Napier grass cutting

Sr. No.	Parameters	Test trial	
		I	II
1	Date of test	09.03.2026	10.03.2026
2	Net test duration (h)	6.5	1.5
3	Avg. height of bush (mm)	2074	2088
4	Avg. thickness of stem of bush at cutting height (mm)	14.99	13.62
5	Avg. No. of bush per m <sup>2</sup>	40	45
6	Avg. mass of bush cut per m <sup>2</sup> (g)	2377.4	2550.4
7	Actual area cut (ha/h)	0.053	0.049
8	Time required for one ha (h/ha)	18.87	20.41
9	Mass of bush cut		
		kg/h	1259.88
		kg/ha	23774
10	Fuel consumption		
		l/h	0.91
		l/ha	17.17

ANNEXURE-IV

DETAILS OF OPERATORS

Operator	:	I	II
Age, years	:	35	38
Height, cm	:	167	170
Weight, kg	:	70	68