

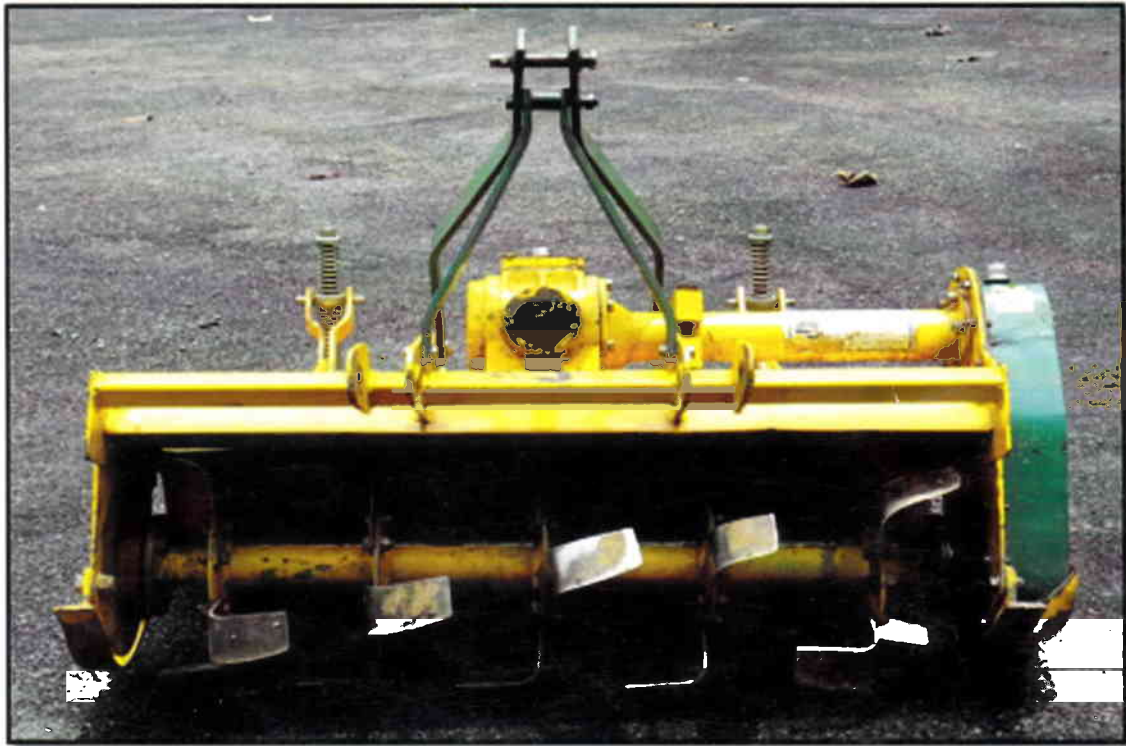

व्यावसायिक परीक्षण रिपोर्ट
COMMERCIAL TEST REPORT

संख्या / No.: Imp.173/226
माह / Month: May, 2015



NEW SWAN (NSE RT 100) ROTAVATOR

Lib. Copy



सत्यमेव जयते

भारत सरकार
GOVT OF INDIA
कृषि मन्त्रालय

MINISTRY OF AGRICULTURE

कृषि एवं सहकारिता विभाग

DEPARTMENT OF AGRICULTURE AND COOPERATION

उत्तर पूर्वी क्षेत्र कृषि यंत्र प्रशिक्षण एवं परीक्षण संस्थान

NORTH EASTERN REGION FARM MACHINERY TRAINING & TESTING INSTITUTE

विश्वनाथ चारिआलि, जिला-शोणितपुर (असम)

BISWANATH CHARIALI :: SONITPUR :: ASSAM, PIN - 784 176

Website: <http://nerfmtti.dacnet.nic.in>

Ph. No. 03715-222094

E-Mail: fmti-ner@nic.in

Fax No: 03715-230358

1777
27/8/15

1. SCOPE OF TEST

The scope of test was to check and assess the following:

1.1 LABORATORY TEST:

- Checking of specifications
- Hardness of soil engaging parts (Rotavator blades)
- Chemical analysis of critical components (Rotavator blades)
- Wear analysis of critical components (Rotavator blades)

1.2 FIELD TEST:

- Rate of work
- Quality of work
- Ease of operation, maintenance and adjustments
- Labour requirement
- Defects, Breakdowns & Repairs

2. METHOD OF SELECTION

The implement was directly submitted by the applicant for test at this Institute, hence method of selection does not arise.

3. TEST PROCEDURES

- | | | |
|---|---|--|
| i) IS: 6690-1981
(Reaffirmed in 2002) | : | Specifications of blades for rotavator and power tillers |
| ii) IS: 4931 – 1995
(Reaffirmed in December 1999) | : | Agricultural tractors-Rear Mounted PTO shaft (Types 1, 2 & 3) |
| iii) IS: 4468 – 1997 (Part-1)
(Reaffirmed in 2012) | : | Agricultural wheeled Tractors- Rear Mounted three point linkage. |
| iv) IS: 11531 – 2001 | : | Test code for puddler |

4. SPECIFICATIONS**4.1 General:**

- | | | |
|-----------------|---|--|
| Manufacturer | : | M/s. New Swan Multitech Limited,
Village Raian, Kohara-Macchiwara
P.O.-Heeran, Ludhiana, Punjab-141112 |
| Name of machine | : | Rotavator |
| Make | : | NEW SWAN |
| Model | : | NSE RT 100 Rotavator |
| Type | : | Gear Drive |

Serial number	: NSE0010856
Year of manufacture	: 2014
Type of blade	: Hatchet (L-Type)
Working width of implement(mm)	: 1035
Recommended power source	: 23-30 HP
Prime mover used during test	: HMT 3522 Tractor (Refer Annexure-III)

4.2 Constructional Details (Refer Fig.1):

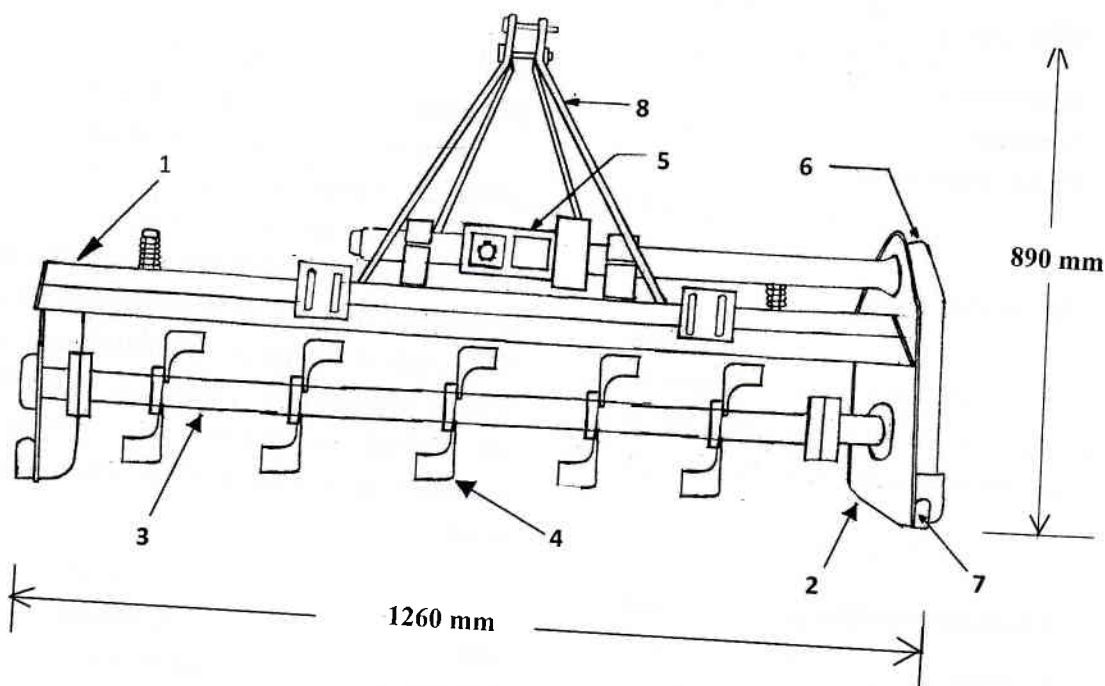

Fig.1: NEW SWAN (NSE RT 100) Rotavator

KEYWORDS:

1. Mainframe
2. Side plate
3. Rotor shaft
4. Rotor blade
5. Primary reduction gear box
6. Secondary reduction gear box
7. Skid
8. Hitch pyramid

Imp. 173/226	New Swan (NSE RT 100) Rotavator [Commercial]	18
--------------	---	----

7.4 Labour requirement

One skilled operator was needed to operate the tractor with the implement.

7.5 Adequacy of power of prime mover as used during test

The power of the prime mover as used during test was found adequate.

7.6 Wear analysis (on mass basis)

Wear of L-type blades (on mass basis) was measured and recorded in ensuing table:

7.6.1 Percentage of wear of rotavator blades on mass basis :

Sl. No.	Initial mass of blade (g)	Mass of blade after 42.3 hours of operation (g)	Difference (g)	Percentage of wear (%) after 42.3 hr	Percentage of wear on hour basis (%)
1.	750.0	712.0	38.0	5.07	0.12
2.	750.0	695.0	55.0	7.33	0.17
3.	750.0	684.0	66.0	8.80	0.21
4.	750.0	709.0	41.0	5.47	0.13
5.	750.0	722.0	28.0	3.73	0.09

Remarks: -The hourly percentage wear of blades on mass basis was recorded as 0.09 to 0.21 %.

7.7 Service and maintenance

Required checking & tightening of all nuts & bolt of the implements especially blade, lower hitch clamps and propeller shafts bolts. The trash and soil wrapped on the rotor axle needed to be removed after the day's operation.

7.8 Ease of operation & adjustments

The operator can easily adjust and control the implement from operator's seat in the field as the adjustments were within the easy reach of operator. However the operator has to get down from the tractor in order to raise/ lower the depth adjusting skid.

8. DEFECTS, BREAKDOWNS AND REPAIRS

Sl. No.	Defects, breakdowns and repairs	Progressive Hours
1	The rotor axle hub was broken after running of 19.0 hours of field operation and replaced with new ones having same specifications.	19.0

9. COMMENTS AND RECOMMENDATIONS

- 9.1 The dimensions of the three point linkage (hitch pyramid) of the rotavator do not conform to Ct. I & Cat. II to IS: 4468-2012. This should be looked into for corrective action for standardization.

- 9.2 Dimensions of PIC and PIC yoke bore of implement, does not conform to IS: 4931-1995 and therefore, it should be looked into for corrective action.
- 9.3 Chemical composition of rotor blades does not conform to IS: 6690-2002. The percentage of carbon, silicon and manganese content in composition of rotavator blade material was recorded as 0.274, 0.219, and 1.072% respectively. The carbon and manganese were observed on lower and higher side respectively. In compared with the relevant Indian Standard. It is therefore, recommended that the material of rotavator blade should be improved and provided as per requirement of Indian Standard.
- 9.4 The rate of work was recorded as 0.17 to 0.23 ha/h at forward speed of 2.14 to 2.64 kmph in dry operation.
- 9.5 The depth of operation was recorded as 7 to 8 cm with soil moisture content of 14 to 17% in medium soil as optimum for Dry land operation. The depth of puddle was recorded as 24.5 to 27.2 cm which is considered as normal for such operation.
- 9.6 The field performance of rotavator was evaluated in medium soil. The hourly rate of wear of blade on mass basis were recorded as 0.09 to 0.21%. The average wear of blade is considered as on higher side.
- 9.7 The rotor hub was broken after 19.0 hours of field operation which implies that the hub strength was not adequate. Hence, it should be improved at production level to encounter the stress or to bear the thrust.
- 9.8 No ingress of mud/or water was noticed during puddling operation. Hence, the rotavator is found suitable for wetland operation (puddling).
- 9.9 Labelling plate was provided only Manufacturer Name, Model, Sl. No. , and Year of manufacture However, labelling plate along with the specifications such as-size of the implement, operating speed, and power requirement are to be provided, during the commercial production of implement.
- 9.10 **Technical literature:**
A booklet, named Instruction manual and Parts list was provided for reference during testing. However, it is recommended to bring out the manuals also in Hindi and other vernacular languages as per IS: 8132-1999.

TESTING AUTHORITY

P.P.RAO SENIOR AGRICULTURAL ENGINEER	P.P.Rao
J.J.R.NARWARE DIRECTOR	Narware

Test conducted and report compiled by : P.C. Dihingia, STA and Anshul Pandey , STA(I)

Imp. 173/226	New Swan (NSE RT 100) Rotavator [Commercial]	20
--------------	---	----

10. APPLICANT'S COMMENTS

Para No.	Our Reference	Applicant's comments
10.1	9.1	We will ensure the same for future production
10.2	9.2	We will ensure the same for future production
10.3	9.3	We will ensure the same for future production
10.4	9.7	We will review the design and improve the same
10.5	9.9	We will ensure the same for future production
10.6	9.10	We will ensure the same for future production

ANNEXURE-I

FIELD PERFORMANCE RESULTS (DRYLAND):

Place of test: NER FMTTI's farm, Biswanath Chariali, Assam.

Tractor used: HMT 3522

Sl. No.	Parameters	Test trails			
		I	II	III	IV
1.	Date of test	04.08.14	07.05.15	08.05.15	11.05.15
2.	Net test duration (h)	3.0	6.3	5.5	5.3
3.	Gear used	L-2			
4.	Furrow length (m)	68	64	82	69
5.	Type of soil	Medium			
6.	Bulk density (g/cc)	1.87	1.96	1.96	1.97
7.	Soil Moisture (%)	17	14	15	14
8.	Previous treatment	Rotavation followed by rain			
9.	Forward speed (kmph)	2.14	2.64	2.64	2.15
10.	Wheel slippage (%)	-1.2	-2.4	-1.2	-2.1
11.	Av. depth (cm)	7	7	7	8
12.	Av. width (cm)	99.0	97.4	96.8	98.4
13.	Area covered (ha/h)	0.17	0.23	0.21	0.18

FARM MACHINERY TRAINING & TESTING INSTITUTE (NER), B. CHARIALI, SONITPUR, ASSAM